

# MASSACHUSETTS INSTITUTE OF TECHNOLOGY

Department of Electrical Engineering and Computer Science

## 6.302 Feedback Systems

Fall Term 2003  
Lab 3 Maglev Project

Issued : November 18, 2003  
Due : Friday, December 5, 2003

---

The purpose of this lab is to build and improve a small magnetic levitation (maglev) system. You will be given a kit to build the basic system (which you can keep after checkoff). After building the basic system, you will evaluate the dynamics of the system and design a compensator for it. You are encouraged to also improve other aspects of the system, such as the sensor, the electromagnet, the electronics, and the levitated object. This lab is an open-ended design project, so be creative!

### Basic System Construction

The structural features of the basic maglev system are shown in Figure 1. The schematic of the drive electronics is shown in Figure 2. The kit you will receive includes all of the parts shown in the schematic (and listed in Figure 3), but does not include the wooden stand or the object for levitation (you will have to provide your own). For this lab, you will need to build the basic system as shown in the figures.

This kit is based on a low-cost design developed by Guy Marsden [1]. In the basic system, the position of the levitated object is sensed by the SS495 Hall-effect sensor. The output voltage of the sensor drives the input of the MIC502 fan-management chip. The fan-management chip produces a pulse-width modulated (PWM) drive signal to the LMD18201 H-bridge chip. This PWM signal adjusts the average current in the solenoid, which controls the magnetic field.

Please use care in the construction of your system. Read the data sheets for each IC in the schematic to familiarize yourself with the behavior and operation of the circuit. While the EECS Department and National Semiconductor have been generous in making these kits available to you, we cannot afford to donate large numbers of parts to you. We will expect every student who receives a kit to complete the lab. While we will be tolerant of reasonable but destructive errors, we have only a very small supply of spares. Build carefully!

### Testing

For the basic system to work, the polarities of the solenoid, the sensor, and the magnet must all be correct. When correct, you should notice that the solenoid repels the magnet when the magnet is too close. You may have to experiment with the polarity of the solenoid winding, the placement of the sensor, and the orientation of the magnet.

An ammeter can assist in verifying correct operation. The input current should be large (up to 0.5 A) if the magnet is too far from or too close to the solenoid. At the operating point, the current consumption for this kit is around 100 mA.

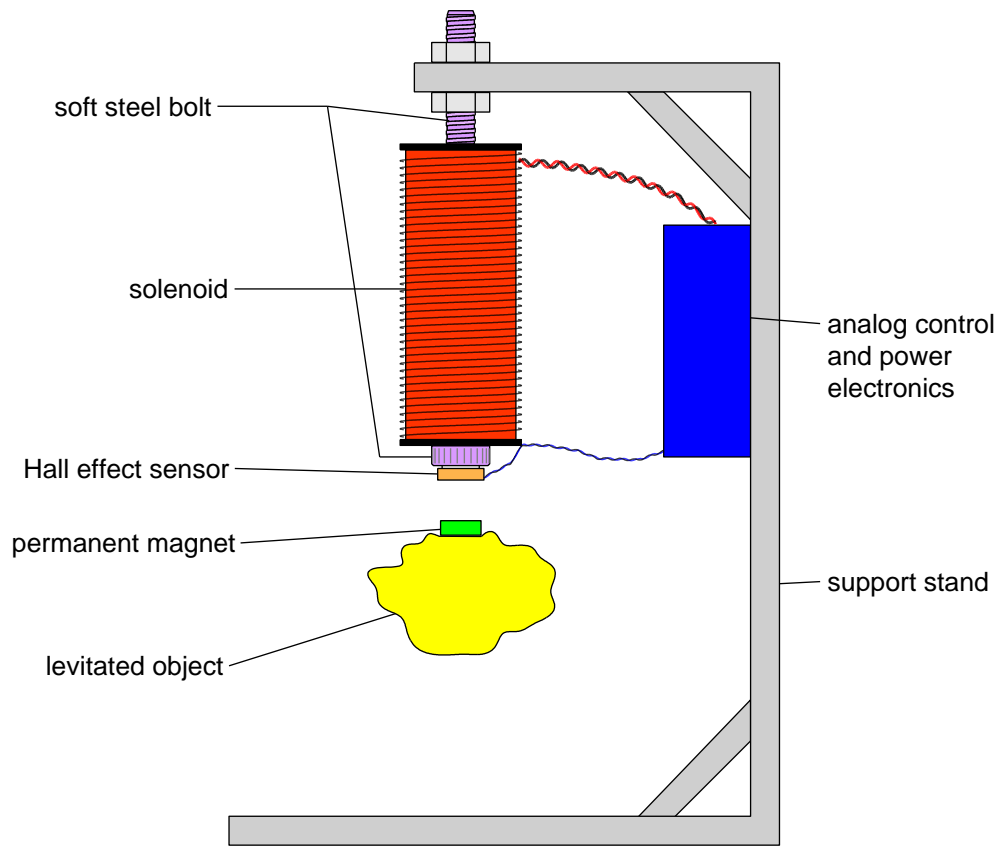

Figure 1: An assembled magnetic levitation system

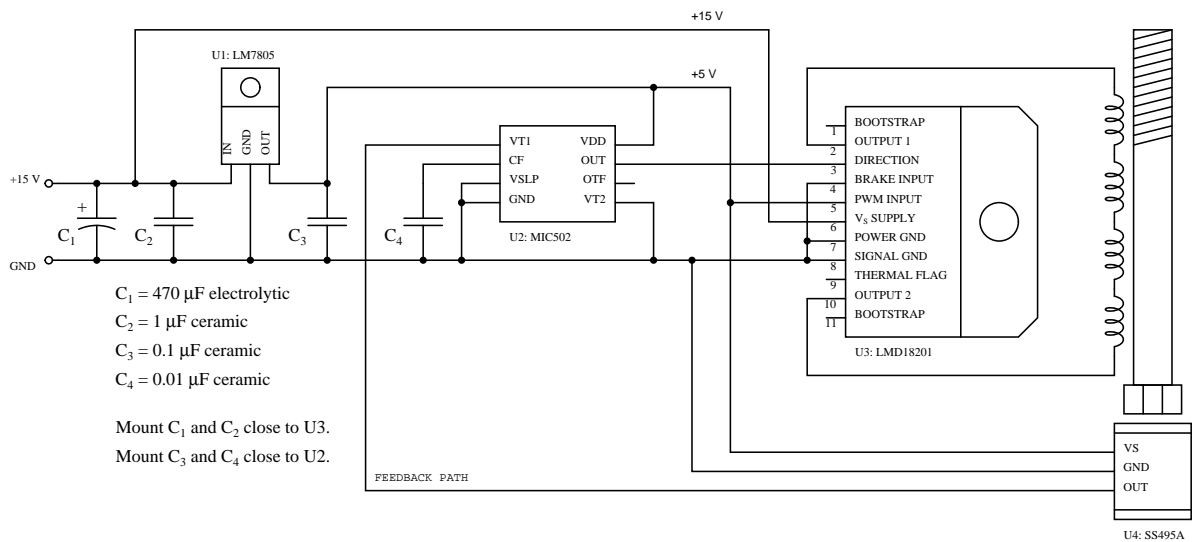

Figure 2: Schematic of magnetic levitation system

U1	LM7805	voltage regulator
U2	MIC502	fan-management IC
U3	LMD18201	motor H-bridge IC
U4	SS495A	Hall-effect sensor
C1	470 $\mu\text{F}$	electrolytic capacitor
C2	1 $\mu\text{F}$	ceramic capacitor
C3	0.1 $\mu\text{F}$	ceramic capacitor
C4	0.01 $\mu\text{F}$	ceramic capacitor
		prewound solenoid
		soft-steel carriage bolt
		neodymium magnets (2)
		heatsink for LMD18201
		small circuit board

Figure 3: List of kit contents

The correct behavior is also very sensitive to the weight of the levitated object. The actual lifting capability of the basic system is very small (about half-a-pencil with the magnet). Be prepared to experiment.

## Compensation

Evaluate the dynamics of the system and design a compensator for it. To evaluate the transient behavior of the improved system, you will need to modify the circuit to provide an input signal, as shown in Figure 4. Measure the step response of the system to small input steps.

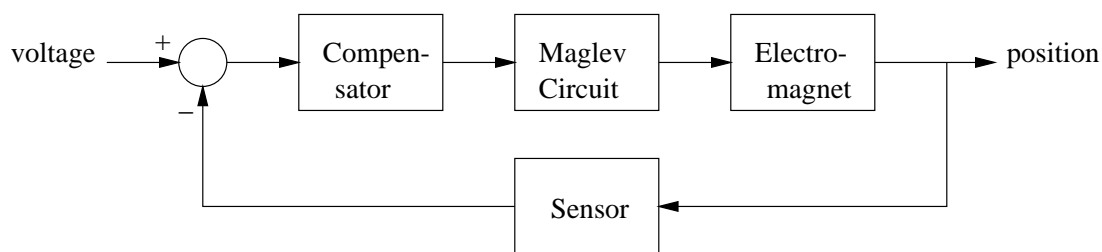

Figure 4: Block diagram of modified magnetic levitation system

Due to the PWM drive to the electromagnet, the output of the sensor may include a lot of ripple. You may wish to filter out this ripple with a low-pass filter before the oscilloscope. Note that this filter does not go inside the feedback loop (for obvious reasons), but goes between the sensor output and the scope.

Design a simple dominant-pole, lag, or lead compensator to stabilize the system and improve the transient response. Design for a peak overshoot of less than 20% in the step response.

## Modifications

You are encouraged to improve other aspects of the system. Modifications to consider include sensor selection and placement, the electromagnet size and design, the characteristics of the levitated object, and the design of the power electronics.

For example, one aspect of the design which can be improved is the position sensor. The Hall-effect sensor detects the strength of the magnetic field produced by the magnet on the levitated object. However, because the Hall-effect sensor is directly below the electromagnet, its output will depend not only on the distance between the sensor and the permanent magnet but also on the strength of magnetic field generated by the solenoid.

The large maglev system analyzed in lecture uses a photo-detector to sense position [2, 3]. In this approach, the steel ball levitates between a collimated light source and the photo-detector to produce a shadow, as shown in Figure 5. This sensor scheme is simple and reliable and can produce a close-to-linear estimation of position. However, it requires careful alignment and additional parts, including a light bulb or LED, a photo-detector (CdS cell), focusing optics, and assorted electronics.

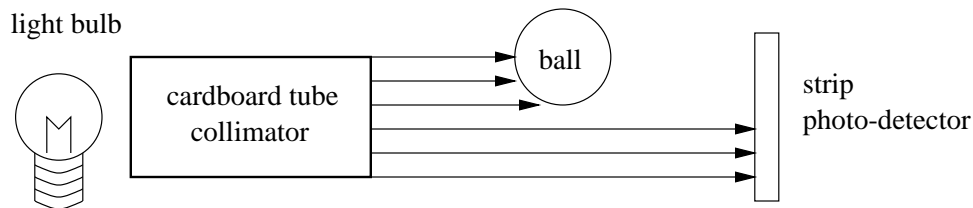

Figure 5: Diagram of simple light sensor system

## Lab Report

Write a report that completely documents your design. In particular,

1. Describe your efforts to evaluate, characterize, and model the basic system. Provide bode plots and transfer functions, if appropriate.
2. Document all changes that you made to the basic system, such as sensor type and location, the electromagnet coil design, the type of levitated object, the power electronics, and (of course) the compensator.
3. Provide complete schematics of any circuitry that you changed in or added to the basic design and describe its function.
4. Describe the behavior of your improved system. Provide step responses, bode plots, and transfer functions.
5. Include references to any books, articles, datasheets, or web sites that you used in your research and design.

Your report should be complete, detailed, and neat. Using your report, a reasonable technician should be able to recreate your design and results.

## Contest

At checkoff, you must demonstrate your improved system to the TAs. A number of system characteristics will be tested and evaluated. Prizes will be awarded for the best designs in the following categories:

Best Transient Response	20 extra credit points
Widest Dynamic Range	20 extra credit points
Best Disturbance Rejection	20 extra credit points
Heaviest Object Lifted	10 extra credit points
Lowest Power Consumption	10 extra credit points
Most Artistic System	Tosci's gift certificate

All entrants must be ready for checkoff starting at 4pm on December 5. Lab reports must be complete at this time. Late entrants will be disqualified.

- 1. Best Transient Response:** Fastest 10–90% risetime to an input step with less than 20% peak overshoot, measured at sensor output.
- 2. Widest Dynamic Range:** Largest periodic movement of the object, measured with a ruler, for a square-wave or sine-wave input.
- 3. Best Disturbance Rejection:** Largest ratio between heaviest object levitated to lightest object levitated, using the same number of magnets.
- 4. Heaviest Object Lifted:** Weight of object, maximum of one magnet.
- 5. Lowest Power Consumption:** Measured with ammeter on the single 15-V supply.
- 6. Most Artistic System:** Beauty is in the eye of the beholder.

Each student may enter up to two categories. Decisions of the judges are final, and may be arbitrary.

## Acknowledgements

Special thanks to National Semiconductor for a generous donation of LMD18201s.

## References

- [1] Guy Marsden, "Levitation!" Nuts and Volts Magazine, vol. 24, no. 9, pp. 58–61, September 2003. Available online at <http://www.arttec.net/Press/N&V/Levitation.html>
- [2] H.H. Woodson and J.R. Melcher. *Electromechanical Dynamics — Part I*. New York: Wiley, 1968. pp. 193–200.
- [3] J.K. Roberge. *Operational Amplifiers: Theory and Practice*. New York: Wiley, 1975. pp. 214–217.